



⇒ Research Article



Chronic Neuroinflammation Induced by Systemic Administration of Lipopolysaccharide Leads to Behavioral Impairments in Mice

Maryam Ghasemi-Kasman^{1,2} , Nahid Davoodian^{3,4} ¹Infertility and Reproductive Health Research Center, Health Research Institute, Babol University of Medical Science, Babol, Iran²Cellular and Molecular Biology Research Center, Health Research Institute, Babol University of Medical Sciences, Babol, Iran³Endocrinology and Metabolism Research Center, Hormozgan University of Medical Sciences, Bandar Abbas, Iran⁴Department of Clinical Biochemistry, Faculty of Medicine, Hormozgan University of Medical Sciences, Bandar Abbas, Iran

Abstract

Background: There is evidence that chronic neuroinflammation is involved in the pathogenesis of neurodegenerative disorders, including Alzheimer's and Parkinson's diseases. In this regard, animal models are considered important tools for the study of neuroinflammation associated with these diseases. The injection of lipopolysaccharide (LPS) is the most commonly used approach for inducing neuroinflammation in animal models. However, there are limited and inconsistent studies regarding the effect of the chronic administration of LPS on behavioral parameters. Accordingly, this experimental study aimed to compare the effect of the chronic injection of LPS in two different doses on behavioral alterations, including spatial learning and working memory in mice.

Methods: Thirty-six male BALB/c mice were used in this study. After acclimatization for a week, mice were randomly divided into three groups. Control mice were intraperitoneally (IP) injected with saline for seven consecutive days, and mice of the second group received 250 µg/kg LPS (IP) dissolved in saline for a week. Finally, mice of the third group were administered 750 µg/kg LPS (IP) dissolved in saline for a week. Morris water maze (MWM) and Y-maze were performed to assess spatial learning and working memory alterations in treated mice, respectively.

Results: It was found that LPS treatment with a high dose (750 µg/kg) results in working memory impairment ($P=0.0024$) and cognitive dysfunction ($P=0.0030$) based on Y-maze and MWM test results.

Conclusion: Our findings suggest that the LPS-induced model of chronic neuroinflammation can be used as an important tool for the investigation of the pathomechanisms of neurodegenerative disorders and the development of new pharmacotherapeutic options.

Keywords: Cognition, Lipopolysaccharide, Neurodegenerative disorders

*Correspondence to

Nahid Davoodian,
Emails: Nahid_Davoodian@
yahoo.com,
Nahid.Davoodian@hums.
ac.ir



Received January 24, 2021, Accepted: April 13, 2021, Published Online: December 6, 2022

Background

It has been demonstrated that the accumulation of misfolded aggregated proteins in different regions of the brain leads to neurodegeneration. During this process, progressive loss of the structure and function of neurons, as well as neuronal death, are found in the affected brain areas (1). Although the exact mechanism/s of neurodegeneration is not completely understood yet, different mechanisms, including oxidative stress and mitochondrial dysfunction, have been suggested for this process (2). In addition, it has been postulated that neuroinflammation has a key role in neurodegeneration.

Several bulks of evidence showed that neuroinflammation has led to cognitive impairments and neurodegenerative diseases, including Alzheimer's (AD), Parkinson's (PD), and Huntington's diseases (3). Experimental data indicated that neuronal cell death induces an inflammatory process, and inflammation by itself may increase the level of cell death (4). To examine the intricate consequences of

neuroinflammation in neurodegeneration, as well as the evaluation of novel therapies, the induction of an inflammation model in animals is necessary.

Different compounds have been used for the induction of neuroinflammation. Among them, lipopolysaccharide (LPS) has been introduced as an effective tool for this purpose (5). LPS is considered the main glycolipid component of endotoxin which is obtained from Gram-negative bacteria cell walls. It has been demonstrated that LPS leads to inflammation, has deleterious effects on organs, and causes septic shock and death (5). Although LPS mainly targets the toll-like receptor (TLR) 4, it also acts on other toll-like receptors (6, 7). A series of downstream adaptors such as myeloid differentiation primary response protein 88 (MyD88), TIR-domain-containing adaptor-inducing interferon- β (TRIF), and TRIF-related adaptor molecule are recruited following the activation of TLR4 by LPS (5). The recruitment of the mentioned adaptors further activates downstream

pathways, increasing the expression of pro-inflammatory genes (8,9). Although LPS is mostly applied for stimulating glial cells, especially microglia, it has been reported that neurons express TLR4 as well. Interestingly, the activation of TLR4 in the neurons increases the production of various inflammatory mediators (5).

LPS not only is applied for *in vitro* studies but also its single or multiple injections are commonly used for the induction of inflammation in the central nervous system (CNS) or the periphery.

It has been shown that various behavioral impairments, including decreased locomotion, weight loss, increased anxiety (10), and cognitive deficit (11-13), occur following LPS injection. These symptoms are mostly similar to the clinical manifestations of neurodegenerative diseases. Therefore, LPS injection is commonly employed to examine neuroinflammation-associated diseases in mice (10). The repeated injection of LPS 3 or 7 times was associated with A β accumulation in the hippocampus and cerebral cortex of mice. In addition, the level of cell death was increased in LPS-treated mice (13). However, the exact mechanisms of LPS-induced cognitive impairments are still unknown (13). Interestingly, LPS induces varied cognitive impairment outcomes regarding the serotype, route of administration, and the number of injections (5). Numerous studies delivered LPS by a single injection or a single dose and a few time points; thus it is impossible to assess the impacts of different time- and dose-dependent changes in neuroinflammation and behaviors (10).

Objectives

There are limited and inconsistent studies regarding the effect of the chronic administration of LPS on behavioral parameters. Accordingly, the present study first examined the effect of the chronic administration of LPS at different doses (250 or 750 μ g/kg) on working memory using the Y-maze test in mice. Furthermore, the Morris water maze (MWM) test was also utilized to assess the levels of spatial learning and memory following LPS injections.

Methods

Animals

This experimental study was performed on male BALB/c

mice. Thirty-six male mice (8-week-old, 25-30 g) were purchased from Royan Institute (Iran). All mice were acclimatized for a week in the university animal room under controlled temperature (21-23 °C), humidity (60-70%), and a 12-hour light/dark cycle with unlimited access to pellet (Pars Animal Food Company, Iran) and water.

Treatment

The schematic presentation of the experimental design is displayed in Figure 1. After acclimatization, mice were randomly divided into three groups. Control mice (n = 12) were intraperitoneally (IP) injected with saline for seven consecutive days. The second group of mice (LPS 250 μ g/kg group, n = 12) received 250 μ g/kg LPS (IP) dissolved in saline for a week (14), and finally, mice of the third group were administered with 750 μ g/kg LPS (IP) (10) dissolved in saline for a week (LPS 250 μ g/kg group, n = 12).

Behavioral Analysis

Behavioral tests, including the MWM test and Y-maze, were conducted to evaluate the effect of LPS on memory functions (Figure 1).

Spontaneous Alteration Performance

A spontaneous alteration test, based on the natural curiosity of rodents for exploring the unvisited area, is used to investigate the spatial working memory of mice. The Y-maze apparatus was built from wood, covered with black paint, consisting of three arms with the equal dimension of 38 \times 8 \times 13 cm (length \times width \times height). To minimize the effect of stress on behavioral tests, mice were habituated to handling two days before the test. After labeling the arms (A, B, C), mice were placed inside arm A and allowed to freely explore the apparatus for 8 minutes. Meanwhile, the sequence of entries in each arm was recorded manually. Finally, the percentage (%) of alteration was calculated using the following formula:

$$\% \text{ of alteration} = \text{Number of alternations} / (\text{total number of arm entries} - 2) \times 100$$

Recognition Memory Test

The recognition memory test was performed as previously

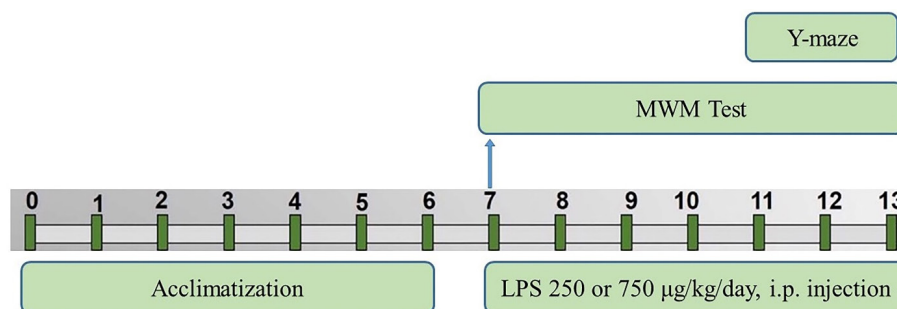

Figure 1. Experimental Design. Note. LPS: Lipopolysaccharide, MWM: Morris water maze. Adult male mice were treated with different doses of LPS for seven consecutive days and then subjected to behavioral tests using MWM tests and Y-maze.

described (15). With one blocked arm, mice were allowed to freely move in the maze for 5 minutes. After 15 minutes of inter-trial intervals, the mice were returned to the maze with three unblocked arms for 2 minutes (test trials). The time spent in the novel arms was recorded and analyzed by the following formula:

$$\text{Recognition memory index} = \frac{\text{The time spent in the novel arm (s)}}{\text{total time spent in all arms (s)}} \times 100$$

Morris Water Maze Test

To assess spatial learning and memory, the MWM test was used as described in our previous report (16). In summary, four 60-second trials were given for each mouse per day, and the training procedure was continued until day 4. Then, the hidden platform was removed on day 5, and mice were permitted to swim for 60 seconds. All experimental results, including the time to find the platform, distance moved, swimming velocity, and time spent in the target quadrant, were recorded using a computer targeting system and analyzed by Neurovision software (Omid Gostar Company, Iran).

Statistical Analysis

Statistical analysis was performed by GraphPad Prism 6 software (GraphPad Software Inc. San Diego, CA, USA). The results of MWM tests, including escape latency, distance moved, and velocity, were analyzed using repeated measure two-way analysis of variance (ANOVA) while taking treatment (saline vs. LPS) and trial (day 1 vs. day 2 vs. day 3 vs. day 4) as between-group variables, followed by Dunnett's post hoc test. The data

from the probe test and Y-maze were analyzed by one-way ANOVA and Dunnett's post hoc test, respectively. The experimental data are presented as the mean \pm SEM (standard error of mean), and $P < 0.05$ was considered to be statistically significant.

Results

LPS With High-Dose Induced Working Memory Impairments in Treated Mice

Two Y-maze tests, including spontaneous alternation and recognition memory tests, were performed to investigate LPS-induced working memory impairments. As illustrated in Figure 2A, a high dose of LPS (750 $\mu\text{g}/\text{kg}$) induced a significant reduction in spontaneous alternations in treated mice compared to the control group ($P = 0.0024$), while no significant difference was observed in a group injected with 250 $\mu\text{g}/\text{kg}$ of LPS (Figure 2A).

A similar trend was also detected for the recognition memory index in which mice treated with 750 $\mu\text{g}/\text{kg}$ of LPS significantly spent less time in the novel arms compared to the control group ($P = 0.0017$). In contrast, the group receiving 250 $\mu\text{g}/\text{kg}$ of LPS spent approximately the same amount of time as the control group in the unvisited arm (Figure 2B).

LPS With High-Dose Induced Spatial Learning and Memory Impairments in Treated Mice

The MWM test was conducted to evaluate the effect of LPS on memory and learning function in treated mice. As depicted in Figure 3A, the escape latency was significantly increased in mice treated with a high dose of LPS (750 $\mu\text{g}/\text{kg}$) compared to the control group in the third ($P = 0.0062$)

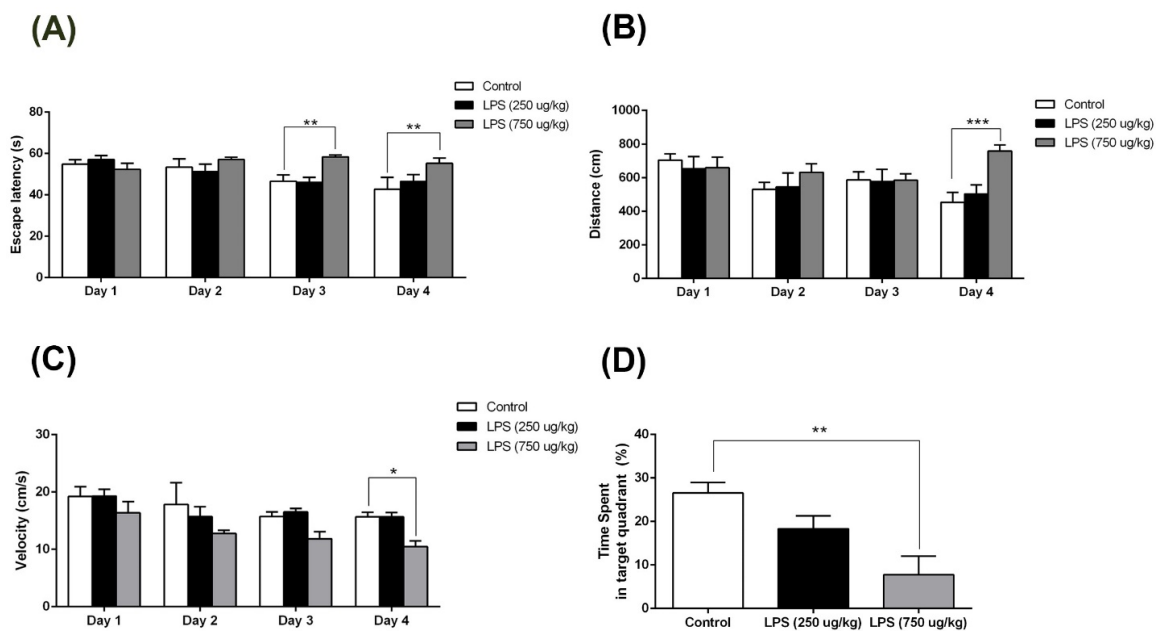

Figure 2. LPS With High-Dose Induced Working Memory Impairments in Treated Mice. Note. LPS: Lipopolysaccharide; ANOVA: Analysis of variance; SEM: Standard error of the mean. Treatment of mice with a high dose of LPS (750 $\mu\text{g}/\text{kg}$) led to impairments in both spontaneous alternation (A) and recognition memory (B) tests compared to control. No significant behavioral impairments were observed in mice treated with a low dose of LPS (250 $\mu\text{g}/\text{kg}$) (A, B). The result of Y-maze was analyzed by one-way ANOVA. Data are expressed as the mean \pm SEM, $n = 12$. ** $P < 0.01$ relative to the control group.

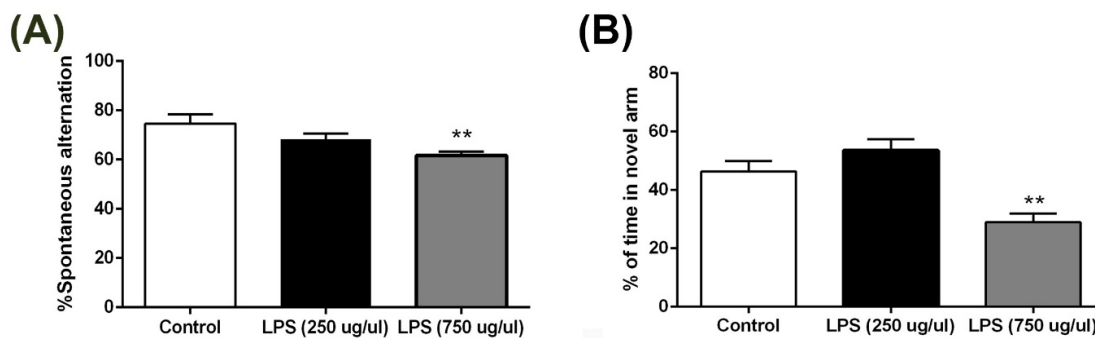

Figure 3. LPS With High-dose Induced Spatial Learning and Memory Impairments in Treated Mice. *Note.* LPS: Lipopolysaccharide; ANOVA: Analysis of variance; SEM: Standard error of the mean. Mice treated with a high dose of LPS (750 µg/kg) showed increased escape latency (A), traveled distance (B), decreased swimming velocity (C), and spent significantly less time in the platform quadrant compared to the control group (D). The result of escape latency, distance moved, and velocity was analyzed by repeated measure two-way ANOVA. The data of the probe test was analyzed via one-way ANOVA. Data are represented as the mean ± SEM, $n=12$. * $P<0.05$, ** $P<0.01$, *** $P<0.001$ relative to the control group.

and fourth ($P=0.0033$) days of the training phase (the main effect of treatment, $F(2, 18)=2.245$, $P=0.1347$; main effect of trial, $F(3, 27)=7.513$, $P=0.0008$; interaction of treatment and trail, $F(6, 54)=2.798$, $P=0.0192$; LPS 750 µg/kg group vs. control group Bonferroni post hoc analysis). In addition, repeated measure two-way ANOVA revealed that LPS with high dose significantly increased the traveled distance to find the platform in comparison to the control group on day 4 of the training trial (the main effect of treatment, $F(2, 18)=3.637$, $P=0.0472$; main effect of trial, $F(3, 27)=1.748$, $P=0.1809$; interaction of treatment and trail, $F(6, 54)=2.393$, $P=0.0401$; LPS 750 µg/kg group vs. control group Bonferroni post hoc analysis, $P=0.004$, Figure 3B). Similarly, swimming velocity was found to significantly decrease in the LPS 750 µg/kg group compared to the control group on day 4 of the training trial (main effect of treatment, $F(2, 18)=10.55$, $P=0.0009$; main effect of trial, $F(3, 27)=3.846$, $P=0.0206$; interaction of treatment and trail, $F(6, 54)=0.3165$, $P=0.9256$; LPS 750 µg/kg group vs. control group Bonferroni post hoc analysis, $P=0.0413$, Figure 3C). However, the LPS 250 µg/kg group showed no significant difference in reaching the hidden platform, swimming velocity, and the total distance on all days of the training trial.

To assess spatial memory, a probe test was conducted on the last day of the experiment (day 5) by removing the platform and analyzing the time spent in the target quadrant. One-way ANOVA analysis result demonstrated that mice treated with a high dose of LPS spent significantly less time in the platform quadrant compared to the control group ($P=0.003$). Nonetheless, no significant difference was observed for the LPS 250 µg/kg group for the percentage of time spent in the target quadrant (Figure 3D).

Discussion

LPS, as a strong inducer of inflammation, is considered an important tool for examining the role of neuroinflammation in cognitive deficits and neurodegenerative disorders (5).

In the present study, the behavioral impairments induced by repeated LPS systemic injection were evaluated with different doses in mice. Our results represented that mice treated with a high dose of LPS (750 µg/kg) exhibited significant cognitive deficits, including impairments in working memory and spatial learning.

Neurodegenerative disorders are debilitating conditions that lead to the progressive damage of the structure and function of the CNS. Currently, available treatment strategies are effective only in a small subset of affected patients and mainly focused on a limited number of symptoms without changing disease progression (17, 18). Despite extensive research, the pathomechanism of these disorders, which severely affect the life quality of patients, remains largely elusive. Among various factors that contribute to the pathogenesis of these diseases, chronic neuroinflammation is known as an important factor involved in the development of several neurodegenerative disorders, including AD and PD (3). Studies have extensively demonstrated that activated microglia and astrocytes induced by inflammatory responses lead to neural damage, disruption in neural connectivity, and subsequently function decline (19). Evidence indicates that neuroinflammation can be a consequence of local injuries such as traumatic brain injury or systematic inflammatory response. In this regard, several studies have suggested a link between inflammatory disorders and the development of neurodegenerative disorders (20-23). Different animal models of neuroinflammation have been established based on these findings (24). The most commonly used approach is LPS, which is injected either in CNS or in the periphery. As of today, various protocols have been recommended in terms of LPS doses, route of injection, and single or repeated injections (5). Accordingly, different neurological and behavioral results have been reported based on the used experimental protocol, as well as animal species and age. Numerous studies have demonstrated that the IP injections of LPS result in increased levels of inflammatory markers, including interleukin 6 (IL-6), tumor necrosis factor α ,

and IL-1 β , in different brain regions (5, 25-28). Moreover, these effects are accompanied by the microglia and astrocytes activation, consequently leading to extensive neural damage (14, 29, 30). Behavioral impairments, including spatial learning and memory deficits, have also been frequently found in systematic LPS challenge models (10, 14, 31). These results support the importance of LPS injection animal models to study the pathomechanisms of neurodegenerative disorders such as AD and PD. However, selecting a suitable route, injection time point, and dose of LPS represent a major challenge.

In the present study, the chronic neuroinflammation IP injections of LPS was induced to examine behavioral alterations in treated mice and provide a suitable model for future studies. For the evaluation of spatial learning and memory, the MWM test was performed six hours after the IP injections of LPS. Compared to the control group, mice treated with a high dose of LPS took a longer time to find the platform on the third and fourth days of the training trial. In addition, chronic neuroinflammation with a high dose of LPS induced spatial memory impairments in the treated mice. To the best of our knowledge, this study is the first one to report working memory impairments in mice treated with a high dose of LPS. Similarly, Zhao et al concluded that LPS (750 μ g/kg) administration for seven consecutive days causes cognitive impairments in treated mice based on the results of the MWM test (10). Spatial working memory impairment was also reported in mice treated with IP LPS (150 μ g/kg) injections for seven days in the Institute of Cancer Research (14). With the same protocol, the intended LPS (500 μ g/kg) systemic injections induced significant cognitive dysfunctions in the treated Wistar rats (32). Consistent with this finding, another study showed that the IP injection of LPS induced increased escape latency and distance traveled in treated mice compared to the control group (33). With an intrahippocampal injection, cognitive dysfunction was also found in another study (34). However, the main drawback of this route of injection is that intrahippocampal injection is complicated and associated with a low survival rate. It is noteworthy that numerous studies are confirming the link between intracerebroventricular injection LPS and cognitive impairments in treated animals. As mentioned earlier, being complicated and time-consuming has made this route difficult to perform (5). Although we did not detect any behavioral impairments in mice treated with a low dose of LPS (250 μ g/kg) compared to the control group, another study demonstrated that the IP injections of LPS (250 μ g/kg) induced memory dysfunction in adult male C57BL/6N mice (31). The reason for this contradiction might be the difference in animal species since the same dose and route of administration were used in these studies. Although the present study suggested an animal model of chronic neuroinflammation, it was only

validated on male animals. Therefore, it is of interest to investigate this model on female mice and use more behavioral experiments to confirm it.

Conclusion

Overall, our results demonstrated that the chronic injections of LPS with high doses could induce spatial and working memory impairments in the treated mice. Our findings also suggested that the LPS-induced model of chronic neuroinflammation can be used as an important tool for the investigation of the pathomechanisms of neurodegenerative disorders and the development of new pharmacotherapeutic options.

Acknowledgments

This research was supported by a grant from the Research Vice-chancellor of Hormozgan University of Medical Sciences (No. 990504).

Author Contributions

Conceptualization: Nahid Davoodian.

Data curation: Nahid Davoodian.

Formal Analysis: Nahid Davoodian, Maryam Ghasemi-Kasman.

Funding acquisition: Nahid Davoodian.

Investigation: Nahid Davoodian, Maryam Ghasemi-Kasman.

Methodology: Maryam Ghasemi-Kasman, Nahid Davoodian.

Project administration: Nahid Davoodian.

Resources: Nahid Davoodian.

Software: Maryam Ghasemi-Kasman.

Supervision: Nahid Davoodian.

Validation: Nahid Davoodian.

Visualization: Nahid Davoodian, Maryam Ghasemi-Kasman.

Writing – original draft: Nahid Davoodian, Maryam Ghasemi-Kasman.

Writing – review & editing: Nahid Davoodian, Maryam Ghasemi-Kasman.

Conflict of Interests

The authors declare no conflict of interests.

Ethical Approval

All experimental procedures were conducted following the National Institutes of Health guide for the care and use of laboratory animals and approved by the Ethics Committee of HUMS (IR. HUMS.REC.1398.422).

References

- Magalingam KB, Radhakrishnan A, Ping NS, Haleagrahara N. Current concepts of neurodegenerative mechanisms in Alzheimer's disease. *Biomed Res Int.* 2018;2018:3740461. doi: [10.1155/2018/3740461](https://doi.org/10.1155/2018/3740461).
- Avila J. Common mechanisms in neurodegeneration. *Nat Med.* 2010;16(12):1372. doi: [10.1038/nm1210-1372a](https://doi.org/10.1038/nm1210-1372a).
- Glass CK, Saijo K, Winner B, Marchetto MC, Gage FH. Mechanisms underlying inflammation in neurodegeneration. *Cell.* 2010;140(6):918-34. doi: [10.1016/j.cell.2010.02.016](https://doi.org/10.1016/j.cell.2010.02.016).
- Ransohoff RM. How neuroinflammation contributes to neurodegeneration. *Science.* 2016;353(6301):777-83. doi: [10.1126/science.aag2590](https://doi.org/10.1126/science.aag2590).
- Batista CRA, Gomes GF, Candelario-Jalil E, Fiebich BL, de Oliveira ACP. Lipopolysaccharide-induced neuroinflammation as a bridge to understand neurodegeneration. *Int J Mol Sci.* 2019;20(9):2293. doi: [10.3390/ijms20092293](https://doi.org/10.3390/ijms20092293).

6. Boonen B, Alpizar YA, Sanchez A, López-Requena A, Voets T, Talavera K. Differential effects of lipopolysaccharide on mouse sensory TRP channels. *Cell Calcium*. 2018;73:72-81. doi: [10.1016/j.ceca.2018.04.004](https://doi.org/10.1016/j.ceca.2018.04.004).
7. Alpizar YA, Boonen B, Sanchez A, Jung C, López-Requena A, Naert R, et al. TRPV4 activation triggers protective responses to bacterial lipopolysaccharides in airway epithelial cells. *Nat Commun*. 2017;8(1):1059. doi: [10.1038/s41467-017-01201-3](https://doi.org/10.1038/s41467-017-01201-3).
8. Zughaier SM, Zimmer SM, Datta A, Carlson RW, Stephens DS. Differential induction of the toll-like receptor 4-MyD88-dependent and-independent signaling pathways by endotoxins. *Infect Immun*. 2005;73(5):2940-50. doi: [10.1128/iai.73.5.2940-2950.2005](https://doi.org/10.1128/iai.73.5.2940-2950.2005).
9. Gray P, Dagvadorj J, Michelsen KS, Brikos C, Rentsendorj A, Town T, et al. Myeloid differentiation factor-2 interacts with Lyn kinase and is tyrosine phosphorylated following lipopolysaccharide-induced activation of the TLR4 signaling pathway. *J Immunol*. 2011;187(8):4331-7. doi: [10.4049/jimmunol.1100890](https://doi.org/10.4049/jimmunol.1100890).
10. Zhao J, Bi W, Xiao S, Lan X, Cheng X, Zhang J, et al. Neuroinflammation induced by lipopolysaccharide causes cognitive impairment in mice. *Sci Rep*. 2019;9(1):5790. doi: [10.1038/s41598-019-42286-8](https://doi.org/10.1038/s41598-019-42286-8).
11. Choi DY, Lee JW, Lin G, Lee YK, Lee YH, Choi IS, et al. Obovatol attenuates LPS-induced memory impairments in mice via inhibition of NF- κ B signaling pathway. *Neurochem Int*. 2012;60(1):68-77. doi: [10.1016/j.neuint.2011.11.005](https://doi.org/10.1016/j.neuint.2011.11.005).
12. Shaw KN, Commins S, O'Mara SM. Lipopolysaccharide causes deficits in spatial learning in the watermaze but not in BDNF expression in the rat dentate gyrus. *Behav Brain Res*. 2001;124(1):47-54. doi: [10.1016/s0166-4328\(01\)00232-7](https://doi.org/10.1016/s0166-4328(01)00232-7).
13. Lee JW, Lee YK, Yuk DY, Choi DY, Ban SB, Oh KW, et al. Neuro-inflammation induced by lipopolysaccharide causes cognitive impairment through enhancement of beta-amyloid generation. *J Neuroinflammation*. 2008;5:37. doi: [10.1186/1742-2094-5-37](https://doi.org/10.1186/1742-2094-5-37).
14. Bahaidrah KA, Alzahrani NA, Aldahri RS, Mansouri RA, Alghamdi BS. Effects of Different Lipopolysaccharide Doses on Short-and Long-Term Spatial Memory and Hippocampus Morphology in an Experimental Alzheimer's Disease Model. *Clinical and Translational Neuroscience*. 2022;6(3):20.
15. Alizadeh F, Davoodian N, Kazemi H, Ghasemi-Kasman M, Shaerzadeh F. Prenatal zinc supplementation attenuates lipopolysaccharide-induced behavioral impairments in maternal immune activation model. *Behav Brain Res*. 2020;377:112247. doi: [10.1016/j.bbr.2019.112247](https://doi.org/10.1016/j.bbr.2019.112247).
16. Hashemian M, Anissian D, Ghasemi-Kasman M, Akbari A, Khalili-Fomeshi M, Ghasemi S, et al. Curcumin-loaded chitosan-alginate-STPP nanoparticles ameliorate memory deficits and reduce glial activation in pentylentetrazol-induced kindling model of epilepsy. *Prog Neuropsychopharmacol Biol Psychiatry*. 2017;79(Pt B):462-71. doi: [10.1016/j.pnpbp.2017.07.025](https://doi.org/10.1016/j.pnpbp.2017.07.025).
17. Gitler AD, Dhillon P, Shorter J. Neurodegenerative disease: models, mechanisms, and a new hope. *Dis Model Mech*. 2017;10(5):499-502. doi: [10.1242/dmm.030205](https://doi.org/10.1242/dmm.030205).
18. Hussain R, Zubair H, Pursell S, Shahab M. Neurodegenerative diseases: regenerative mechanisms and novel therapeutic approaches. *Brain Sci*. 2018;8(9):177. doi: [10.3390/brainsci8090177](https://doi.org/10.3390/brainsci8090177).
19. Tremblay M, Stevens B, Sierra A, Wake H, Bessis A, Nimmerjahn A. The role of microglia in the healthy brain. *J Neurosci*. 2011;31(45):16064-9. doi: [10.1523/jneurosci.4158-11.2011](https://doi.org/10.1523/jneurosci.4158-11.2011).
20. Holmes C. Review: systemic inflammation and Alzheimer's disease. *Neuropathol Appl Neurobiol*. 2013;39(1):51-68. doi: [10.1111/j.1365-2990.2012.01307.x](https://doi.org/10.1111/j.1365-2990.2012.01307.x).
21. Ledesma MD, Dotti CG. Peripheral cholesterol, metabolic disorders and Alzheimer's disease. *Front Biosci (Elite Ed)*. 2012;4(1):181-94. doi: [10.2741/e368](https://doi.org/10.2741/e368).
22. McGeer PL, McGeer EG. The amyloid cascade-inflammatory hypothesis of Alzheimer disease: implications for therapy. *Acta Neuropathol*. 2013;126(4):479-97. doi: [10.1007/s00401-013-1177-7](https://doi.org/10.1007/s00401-013-1177-7).
23. Spielman LJ, Little JP, Klegeris A. Inflammation and insulin/IGF-1 resistance as the possible link between obesity and neurodegeneration. *J Neuroimmunol*. 2014;273(1-2):8-21. doi: [10.1016/j.jneuroim.2014.06.004](https://doi.org/10.1016/j.jneuroim.2014.06.004).
24. Hamasaki MY, Machado MCC, Pinheiro da Silva F. Animal models of neuroinflammation secondary to acute insults originated outside the brain. *J Neurosci Res*. 2018;96(3):371-8. doi: [10.1002/jnr.24184](https://doi.org/10.1002/jnr.24184).
25. Bossù P, Cutuli D, Palladino I, Caporali P, Angelucci F, Laricchiuta D, et al. A single intraperitoneal injection of endotoxin in rats induces long-lasting modifications in behavior and brain protein levels of TNF- α and IL-18. *J Neuroinflammation*. 2012;9:101. doi: [10.1186/1742-2094-9-101](https://doi.org/10.1186/1742-2094-9-101).
26. Brugg B, Dubreuil YL, Huber G, Wollman EE, Delhaye-Bouchaud N, Mariani J. Inflammatory processes induce beta-amyloid precursor protein changes in mouse brain. *Proc Natl Acad Sci U S A*. 1995;92(7):3032-5. doi: [10.1073/pnas.92.7.3032](https://doi.org/10.1073/pnas.92.7.3032).
27. Erickson MA, Hansen K, Banks WA. Inflammation-induced dysfunction of the low-density lipoprotein receptor-related protein-1 at the blood-brain barrier: protection by the antioxidant N-acetylcysteine. *Brain Behav Immun*. 2012;26(7):1085-94. doi: [10.1016/j.bbi.2012.07.003](https://doi.org/10.1016/j.bbi.2012.07.003).
28. Marottoli FM, Katsumata Y, Koster KP, Thomas R, Fardo DW, Tai LM. Peripheral inflammation, apolipoprotein E4, and amyloid- β interact to induce cognitive and cerebrovascular dysfunction. *ASN Neuro*. 2017;9(4):1759091417719201. doi: [10.1177/1759091417719201](https://doi.org/10.1177/1759091417719201).
29. Katafuchi T, Ifuku M, Mawatari S, Noda M, Miake K, Sugiyama M, et al. Effects of plasmalogens on systemic lipopolysaccharide-induced glial activation and β -amyloid accumulation in adult mice. *Ann NY Acad Sci*. 2012;1262:85-92. doi: [10.1111/j.1749-6632.2012.06641.x](https://doi.org/10.1111/j.1749-6632.2012.06641.x).
30. Wang LM, Wu Q, Kirk RA, Horn KP, Ebada Salem AH, Hoffman JM, et al. Lipopolysaccharide endotoxemia induces amyloid- β and p-tau formation in the rat brain. *Am J Nucl Med Mol Imaging*. 2018;8(2):86-99.
31. Khan A, Ali T, Rehman SU, Khan MS, Alam SI, Ikram M, et al. Neuroprotective effect of quercetin against the detrimental effects of LPS in the adult mouse brain. *Front Pharmacol*. 2018;9:1383. doi: [10.3389/fphar.2018.01383](https://doi.org/10.3389/fphar.2018.01383).
32. Behairi N, Belkhefama M, Rafa H, Labsi M, Deghbar N, Bouzid N, et al. All-trans retinoic acid (ATRA) prevents lipopolysaccharide-induced neuroinflammation, amyloidogenesis and memory impairment in aged rats. *J Neuroimmunol*. 2016;300:21-9. doi: [10.1016/j.jneuroim.2016.10.004](https://doi.org/10.1016/j.jneuroim.2016.10.004).
33. Hou Y, Xie G, Liu X, Li G, Jia C, Xu J, et al. Minocycline protects against lipopolysaccharide-induced cognitive impairment in mice. *Psychopharmacology (Berl)*. 2016;233(5):905-16. doi: [10.1007/s00213-015-4169-6](https://doi.org/10.1007/s00213-015-4169-6).
34. Huang HJ, Chen YH, Liang KC, Jheng YS, Jhao JJ, Su MT, et al. Exendin-4 protected against cognitive dysfunction in hyperglycemic mice receiving an intrahippocampal lipopolysaccharide injection. *PLoS One*. 2012;7(7):e39656. doi: [10.1371/journal.pone.0039656](https://doi.org/10.1371/journal.pone.0039656).